



Reliability & efficiency without compromise

Rotary Screw Compressors



Premium compressor design
and industry leading warranty

L-Series
7 – 11 kW
Fixed & Regulated Speed

Good - Better - **Best Efficiency**

The **L-Series** from CompAir

Well known in the industry for quality and reliability, CompAir continuously develops and expands the L-Series to achieve optimum performance and efficiency and maximum flexibility. The wide range of screw compressors from 7 to 11 kW includes fixed and regulated speed models, high efficiency e-models and is available as airstation including receiver and refrigerant dryer.

Standard Range

Fixed & Regulated Speed

- ▶ **Pressure range**
5 to 13 bar
- ▶ **Volume flow**
0.43 to 1.59 m³/min
- ▶ **Motor power**
7.5 to 11 kW



e Range

Fixed & Regulated Speed

- ▶ **Pressure range**
5 to 13 bar
- ▶ **Volume flow**
0.41 to 1.87 m³/min
- ▶ **Motor power**
7.5 to 11 kW



“ Known for reliability, continuously developed in efficiency, extended with flexibility, unmatched in terms of warranty.

Engineering **excellence**

Compressors are more than just a financial investment, they are a key component in ensuring that manufacturers, processors and operators receive consistent, high quality low cost air. The screw compression element is the heart of the compressor and therefore CompAir keeps the design and manufacture in-house, using the latest CNC rotor grinding machinery, coupled with online laser technology. The resulting reliability and performance ensure that operating costs will remain low throughout the compressor's life.

Our top quality airends are covered by the new 10 years warranty and up to 44,000 hours*

The dryers too are designed and manufactured in-house – the customer designed heat exchangers and patented control board delivering the very best combination of high efficiency, low pressure drop and small footprint.

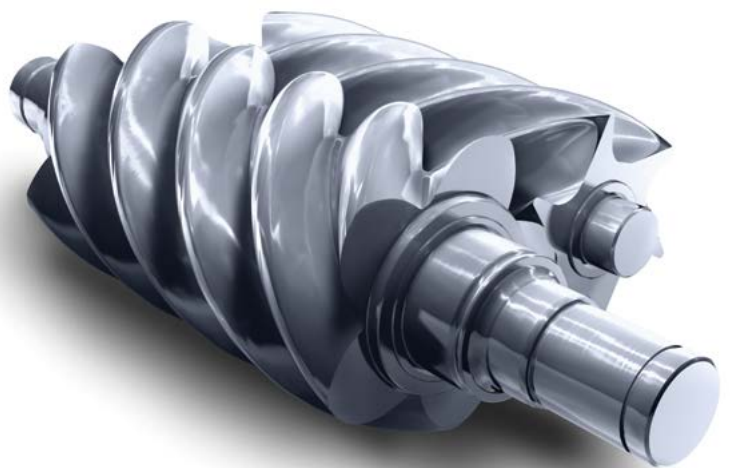

Under the new Assure warranty, which is completely free of charge, the airends are **covered 10 years and up to 44,000 hours.**

* Whichever is soonest

The right product to do the job

Standard range L07 to L11, RS Fixed & regulated speed

Based on the individual customer requirements, the compressors can be combined with different options to provide maximum flexibility. The combined versions including receiver or/and dryer are space saving solution – ideal where floor space is precious.

- Compressor base mounted
- Complete package including compressor, dryer and receiver

The stand alone compressors feature a very compact design with a class-leading footprint of just 0,4 m². In the combination with dryer and receiver the floor space can be optimised, in addition the installation is very easy.

SMALL FOOT PRINT

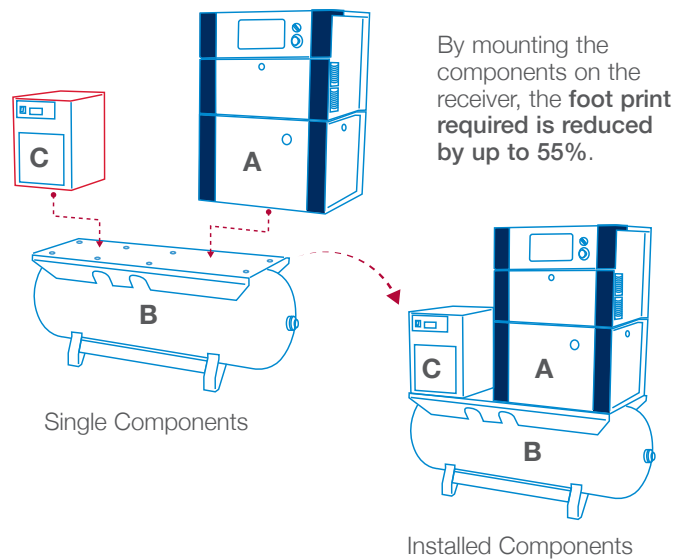

In-house made airend

The high quality airends use state-of-the-art manufacturing techniques. They are designed with focus on reliability and efficiency. The rotors are accurate and thoroughly checked and measured by a computerised control system. The airends achieve a flat specific power consumption curve, which enables efficient use in wide rpm range.

TOP VIEW

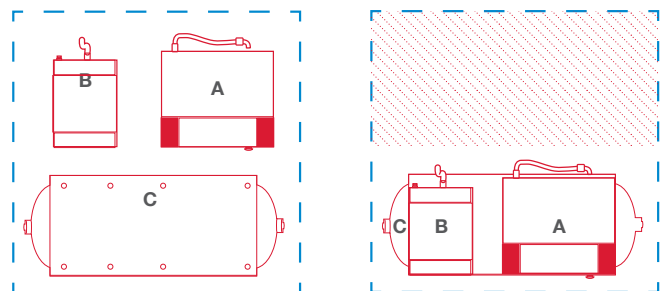

Minimum floor space required

$A + B + C = 1.25 \text{ m}^2$ (L07 - L11) $A + B + C = 3.9 \text{ m}^2$

“ This range of screw compressors allows for ambient temperatures up to 46°C. The generously sized ventilation system ensures optimum cooling, low outlet air temperatures.



New advanced controller C-PRO 2.0 Ensures reliable operation and protecting your investment by continuously monitoring the operational parameters

The C-PRO 2.0 controller is designed to make the operators' interface with the variable speed drive transparent. This new generation controller features extra functions for variable speed compressors like drive status display and flexible PID setting according the application. You don't need to be an expert on variable speed drives to operate your compressor. The controller takes care of the details and automatically adjusts the compressor performance to meet your changing air system demands - saving you energy. Changing the discharge pressure is as easy as pressing a button.

- 3 analog inputs
- Multi-language
- Standard sequence control up to 8 units (up to 7 units fixed speed & 1 variable speed)
- Standard Modbus
- 15 failure records in memory
- Continuous system monitoring

Highly Efficient Motors

The range is equipped with reliable and highly efficient electric motors.

- International efficiency class 2 (IE3) as a standard
- IP 55 enclosure
- Full performance up to 46°C ambient temperature

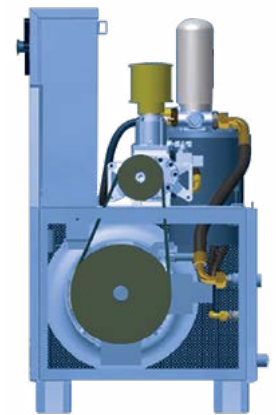
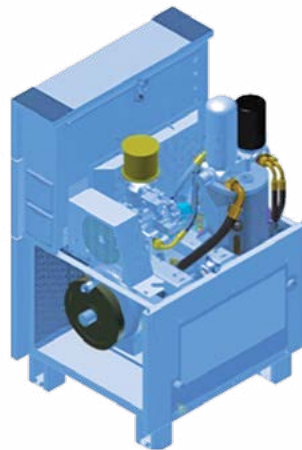

Belt Auto Tensioning system

Easy maintenance

The compressors are designed to ensure easy access to the maintenance points. The panels can be easily removed and the limited number of moving parts reduces service costs.

The automate tensioning of the belt assures long life of the belt, less maintenance and noise reduction.

Best efficiency – Made in Germany

e-Range highly efficient compressors, fixed and regulated speed

The e-range of the L-Series are designed and manufactured in the Center of Excellence in Simmern, Germany. The most important component of a compressor, the airend, is also produced on this site. The engineering team develop airends which perfectly match the compressor requirements and achieve highest performance and efficiency levels. The engineering and manufacturing teams are proud to build this range, which is known in the market not only for the efficiency but also for the flexibility it offers. The compressors are available mounted on a receiver and with a dryer, providing a compact solution and minimum space requirement.



A design concept based on reliability and flexibility

► Fully integrated airend

The advanced design of the high efficiency airend allows operation at low rotational speeds, and consequently lowers the energy costs. The innovative integrated design, including oil separation, oil filter and thermostatic valve, reduces the number of external hoses and components offering excellent reliability.

► Combined air/oil cooler

Equipped with a bypass for rapid warm-up and control of the oil temperature, reducing wear, eliminating condensate in the compressor system and providing low air discharge temperature.

► High efficiency electric motor

The compressors are equipped with an energy saving IE3 electric motor.

► Automatic belt tensioning system

The maintenance-free system provides automatic and accurate belt tension and extends the belt life.

► Factory-filled lubricant

Reduces service costs by extending the oil change period to up to 4,000 hours.

► Low noise levels

Allows the compressor to be placed at the point of use.

► Up to 45°C ambient temperature

Reliable operation, even in challenging environments.

“

It is exactly the quality you would expect from a company with a heritage of more than 200 years.

AirOnDemand

Delcos Pro SE compressor controller

The control system ensures reliable operation and protects the investment by continuously monitoring the operational parameters. The Delcos Pro SE also has the capability to have programmable inputs and outputs, control additional equipment as well as providing the following features in clear readable text from a 2.8" Graphic Display with modern user interface:



- Discharge/line pressure display
- Air/oil temperature display
- Total hours run and under load
- Service due indicator
- Enhanced fault log monitor
- Real time clock
- Timer controlled stop/start
- Remote start/stop
- Auto restart after power failure
- Second pressure setting
- Status indication
- RS485 - Modbus RTU
- Micro-SD-Card for alarm - & data logging
- Integrated BLS-Functionality & Integrated Web-Server Light Via or with
Optional module for RS485 interface & Ethernet connection

Ergonomic controller positioning

Controller can be positioned on top or front of the compressor.



AirPlus

The perfect response to individual air demand

Regulated speed compressors from CompAir can efficiently and reliably handle the varying air demand found in most plant air systems.

The annual cost of ownership can be significantly reduced using regulated speed technology.

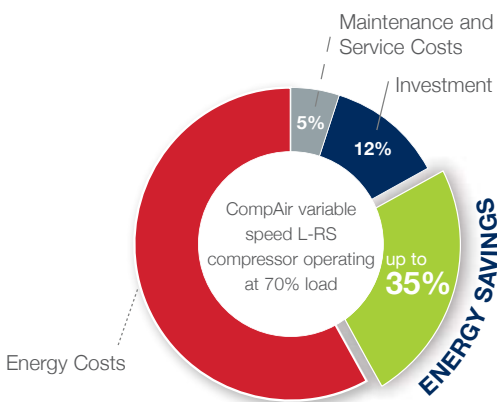

CompAir RS features are your benefits

The L-RS Series products are designed to obtain the greatest efficiency across the entire operating range.

- ▶ **Wide regulation range**
No cycles means substantial energy savings
- ▶ **Perfect motor - drive - air end design**
High efficiency across broad flow range



Compressed air purification

Modern production systems and processes demand increasing levels of air quality. Air treatment products **manufactured by CompAir**, utilise the latest technology and provide an energy-efficient solution at the lowest life cycle costs.

The new downstream portfolio manufactured by CompAir utilising the latest technology, provides an energy efficient solution at lowest life cycle costs. The same quality, performance and efficiency standards delivered by the compressors can now be enjoyed from the air treatment range.

Investment in a manufacturing site in addition to the support teams, ensures that compressed air operators don't need to worry about the quality of their compressed air – quality that is key to ensuring maximum production efficiency and investment protection.

- Water Cyclone Separators
- Compressed Air Filters
- Condensate Drain System
- Compressed Air Refrigerant Dryer
- Heatless Desiccant Dryers
- Heat Regenerative Desiccant Dryers
- Nitrogen Generator
- SmartAir Master Plus Multi Compressor Controllers

The best investment protection you can get

The CompAir Assure Service and Warranty agreements

Cover the air end for up to 10 years.



Your benefits:

It All Adds Up to Peace of Mind

Lower Cost of Ownership

Assure Service and Warranty Agreements provide the most cost-effective solutions based on your customised maintenance strategy.

Quality Results

Factory trained technicians allows you to focus on your core business, while they take care of your compressor system.

Increased Uptime

Service & Warranty Agreements help decrease unplanned downtime and costly production interruptions.

Efficient Energy Use

Peak system efficiency is achieved through properly performed maintenance and inspection.

Peace of Mind

Assure Service agreements ensures an extended warranty. Depends on duration.



¹⁾ 10 years/44,000 hours on the air end. Whichever is the soonest. Subject to Terms & Conditions.

CompAir genuine spare parts

Enjoy complete peace of mind.

Genuine CompAir parts and lubricants ensure that compressed air plant reliability and efficiency is maintained at the highest standards. CompAir spare parts and lubricants are distinguished by:

- Long service life, even under harshest conditions
- High reliability improves plant up-time
- Minimum losses contributing to energy savings
- Products manufactured with the strictest Quality Assurance Systems



CompAir L-Series

- Technical Data

Standard Range

L07 - L11 Fixed Speed

Compressor Model	Nominal Pressure	Drive Motor	FAD ¹⁾		Noise Level ²⁾	Weight	Dimensions L x W x H [mm]
	[bar g]		[kW]	[m ³ /min]			
L07	7	7.5	1.14		70	205	667 x 630 x 1050
	8		0.99				
	10		0.97				
	13		0.80				
L11	7	11	1.59		70	219	667 x 630 x 1050
	8		1.58				
	10		1.39				
	13		1.14				

L07 RS - L11 RS Regulated Speed

Compressor Model	Nominal Pressure [bar g]	Drive Motor [kW]	FAD ¹⁾ [m ³ /min]		Noise Level at 70% load ²⁾ [dB(A)]	Weight [kg]	Dimensions L x W x H [mm]
			min.	max.			
L07 RS	7	7.5	0.45	1.13	67	225	667 x 630 x 1050
	8		0.46	0.98			
	10		0.43	0.95			
	13		0.45	0.77			
L11 RS	7	11	0.53	1.58	67	234	667 x 630 x 1050
	8		0.52	1.56			
	10		0.51	1.39			
	13		0.49	1.07			

L07 - L11 / L07 RS - L11 RS Airstation

Compressor Model	Nominal Pressure [bar g]	Refrigeration Dryer ³⁾	Air Receiver [Volume]		Air Outlet	Weight [kg]	Dimensions L x W x H [mm]
			270 litres	500 litres			
L07 / L07RS	7	✓	270 litres	500 litres	RP ¾"	340 / 360	1540 x 676 x 1550
			500 litres	405 / 425		1885 x 700 x 1643	
	8		270 litres	500 litres		340 / 360	1540 x 676 x 1550
			500 litres	405 / 425		1885 x 700 x 1643	
	10		270 litres	500 litres		340 / 360	1540 x 676 x 1550
			500 litres	405 / 425		1885 x 700 x 1643	
L11 / L11RS	7	✓	270 litres	500 litres	RP ¾"	354 / 369	1540 x 676 x 1550
			500 litres	419 / 434		1885 x 700 x 1643	
	8		270 litres	500 litres		354 / 369	1540 x 676 x 1550
			500 litres	419 / 434		1885 x 700 x 1643	
	10		270 litres	500 litres		354 / 369	1540 x 676 x 1550
			500 litres	419 / 434		1885 x 700 x 1643	

e - Range

L07° - L11° Fixed Speed

Compressor Model	Nominal Pressure	Drive Motor	FAD ¹⁾		Noise Level ²⁾	Weight	Dimensions L x W x H [mm]
	[bar g]		[kW]	[m ³ /min]			
L07°	7.5	7.5	1.30		70	215	667 x 630 x 1050
	10		1.06				
	13		0.85				
L11°	7.5	11	1.87		70	225	667 x 630 x 1050
	10		1.61				
	13		1.32				

L07° RS - L11° RS Regulated Speed

Compressor Model	Nominal Pressure [bar g]	Drive Motor [kW]	FAD ¹⁾ [m ³ /min]		Noise Level at 70% load ²⁾ [dB(A)]	Weight [kg]	Dimensions L x W x H [mm]
			min.	max.			
			L07° RS	7.5			
10	0.44	1.01					
13	0.41	0.83					
L11° RS	7.5	11	0.63	1.81	64	231	667 x 630 x 1050
	10		0.64	1.56			
	13		0.57	1.26			

L07° - L11° / L07° RS - L11° RS Tank Mounted

Compressor Model	Nominal Pressure	Drive Motor	Air Receiver [Volume]	Air Outlet	Weight	Dimensions L x W x H [mm]
	[bar g]					
L07° / L07° RS	7.5	7.5	270 litres	RP ¾"	320 / 337	1541 x 695 x 1577
	10					
	13					
L11° / L11° RS	7.5	11	270 litres	RP ¾"	335 / 347	1541 x 695 x 1577
	10					
	13					

L07° - L11° / L07° RS - L11° RS Airstation

Compressor Model	Nominal Pressure	Refrigeration Dryer ³⁾	Air Receiver [Volume]	Air Outlet	Weight	Dimensions L x W x H [mm]
	[bar g]					
L07° / L07° RS	7.5	✓	270 litres	RP ¾"	356 / 373	1541 x 695 x 1577
	10					
	13					
L11° / L11° RS	7.5	✓	270 litres	RP ¾"	371 / 383	1541 x 695 x 1577
	10					
	13					

¹⁾ Data measured and stated in accordance with ISO 1217 Ed. 4, Annex C & Annex E and the following conditions:

Air Intake Pressure 1 bar a, Air Intake Temperature 20°C, Humidity 0% (dry)

²⁾ Measured in free field conditions in accordance with ISO 2151 and ISO 9614-2, tolerance ± 3 dB(A).

³⁾ The refrigerant dryer requires a separate electric supply. Data refer to DIN ISO 7183, 8573-1:2010

(class 4, pressure dew point 3°C). For further specifications please refer to refrigerant dryer documentation.

Innovation & Engineering Excellence



A leading global manufacturer of a wide range of world-class compressed air solutions, CompAir is dedicated to providing a complete solution for our industry partners. From the latest advances in oil-free and oil-lubricated technologies to a complete range of downstream equipment, air treatment and accessories.

An extensive network of dedicated CompAir sales companies and premium partners across all continents provide global expertise with a truly local service, ensuring our advanced technology is backed up with the right support.

CompAir has consistently been at the forefront of compressed air systems development, culminating in some of the most energy efficient and low environmental impact compressors on the market today, helping customers achieve or surpass their sustainability targets.

CompAir compressed air product range

Advanced Compressor Technology Lubricated

- Rotary Screw
 - > Fixed and Regulated Speed
- Portable
- Vane

Oil-Free

- Water Injected Screw
 - > Fixed and Regulated Speed
- Two Stage Screw
 - > Fixed and Regulated Speed
- Rotary Scroll
- Ultima®

Complete Air Treatment Range

- Filter
- Refrigerant and Desiccant Dryer
- Condensate Management
- Heat of Compression Dryer
- Nitrogen Generator

Modern Control Systems

- CompAir DELCOS Controllers
- SmartAir Master Plus Sequencer
- iConn - Smart Compressor Service

CompAir policy is one of continuous improvement and we therefore reserve the right to alter specifications and prices without prior notice. All products are sold subject to the Company's conditions of sale.

Value Added Services

- Professional Air Audit
- Performance Reporting
- Leak Detection

Leading Customer Support

- Custom Engineered Solutions
- Local Service Centres
- Genuine CompAir Parts and Lubricants